

# Tstat10 Fully Programmable Thermostat

## Description

Tstat10 Bacnet programmable controller is a low cost high performance programmable controller. With an I/O configuration, it can be extended through external I/O modules to form a complete building automation solution.

There are five relays and two analog outputs as well as 8 universal inputs. These i/o can be configured using the free software. There are more than 300 settings with many options for each of the settings so its possible to configure these devices for most any application. Once the unit is configured, save the config file for copying to other controllers and backing up project settings. Options are available for occupancy sensor, zigbee, and humidity / enthalpy. Supports Bacnet MSTP and Modbus RTU for the RS485 model.

Wifi version supports Bacnet IP and Modbus IP



## Fully Programmable

Setup and programming are done on a PC not necessary to connect to live hardware as it is the case with many systems. when the program is ready for on-site testing, connect it to a live panel and download the T3000 software. Programming can be done remotely over the network and modem connections as well. The network system is very flexibile and economical for the installation.

## T3000SoftWare

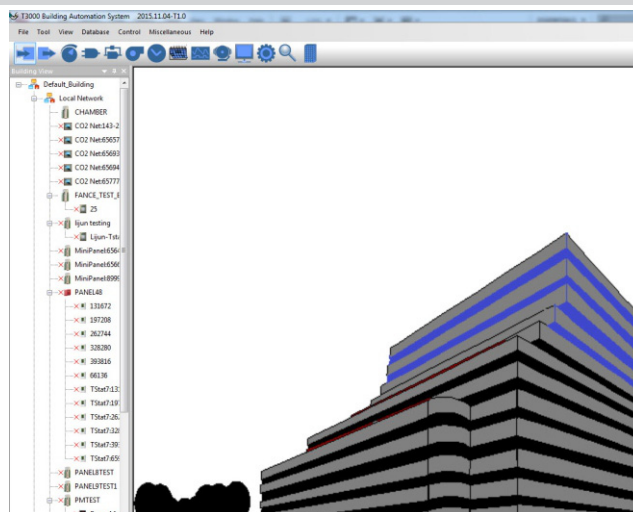

## Highlights

- Software configure the I/O ranges with the free T3000 software or by writing to the registers with your own software
- Universal I/O can be configured for nearly any sensor, no jumper settings required
- Well documented register list for easy integration with other systems.
- 8 universal inputs for external temperature sensors, contacts, etc.
- 5 relay outputs, each rated at 12~24vac, 2 amps
- 2 analog outputs, 0-10V @ 100ma.
- Color LCD display with scroll bar.
- Each I/O as well as the RS485 connections have a separate screw terminal
- Clock with infinite life supercap battery backup.
- Supports Modbus RTU and Bacnet protocols simultaneously.

## Typical Application

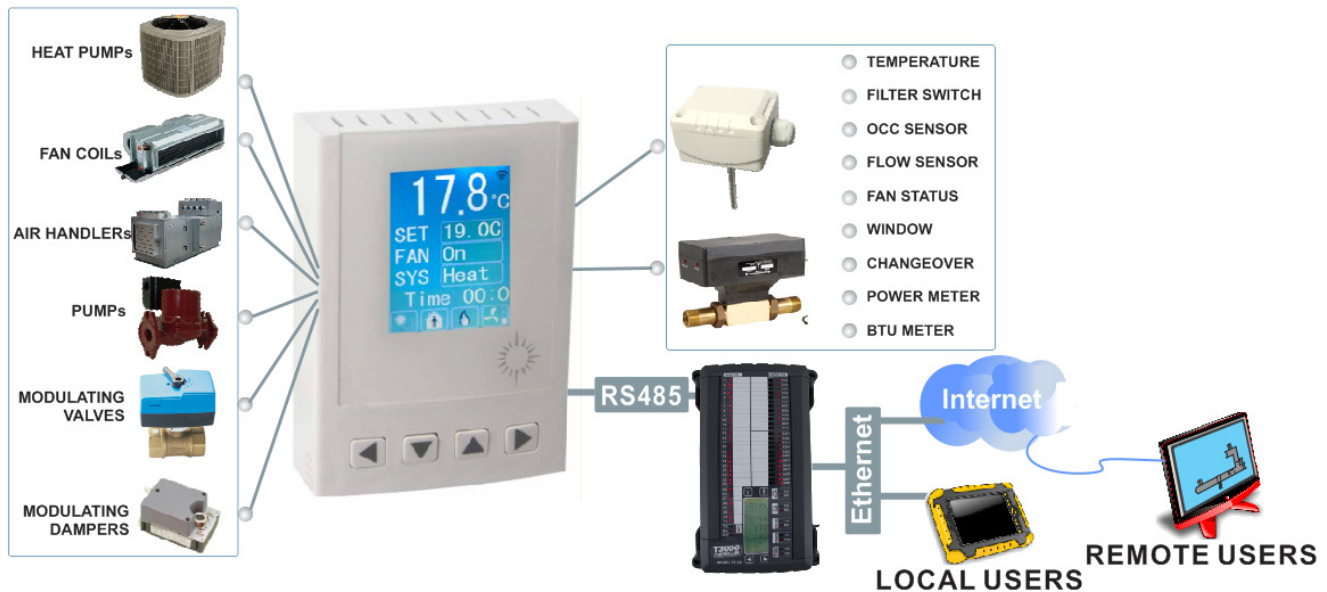

## Specifications

Outputs	5 relay outputs    2 analog outputs 10V@100mA
8 Universal Inputs	10k therm, contacts, 4-20ma, 0-5V, 0-10V
Operating range	-30~70°C(-22~158°F) / 0 to 99% RH
Supply voltage	12~24VAC/DC ±20%, 50-60Hz
Power consumption	100mA at 12VDC
Relay contacts	5 relays, 2A @ 24VAC    UL File No.: E169380
Plastic Housing	Flammability rating UL 94 file E56070
Enclosure rating	IP31
Protocols	Bacnet MSTP and Modbus RTU
Baudrate	9600, 19200, 38400, 57600, 115200
Temperature sensor	10K thermistor ±0.5°C
Setup Software	Free, no licensing, open source

# Size

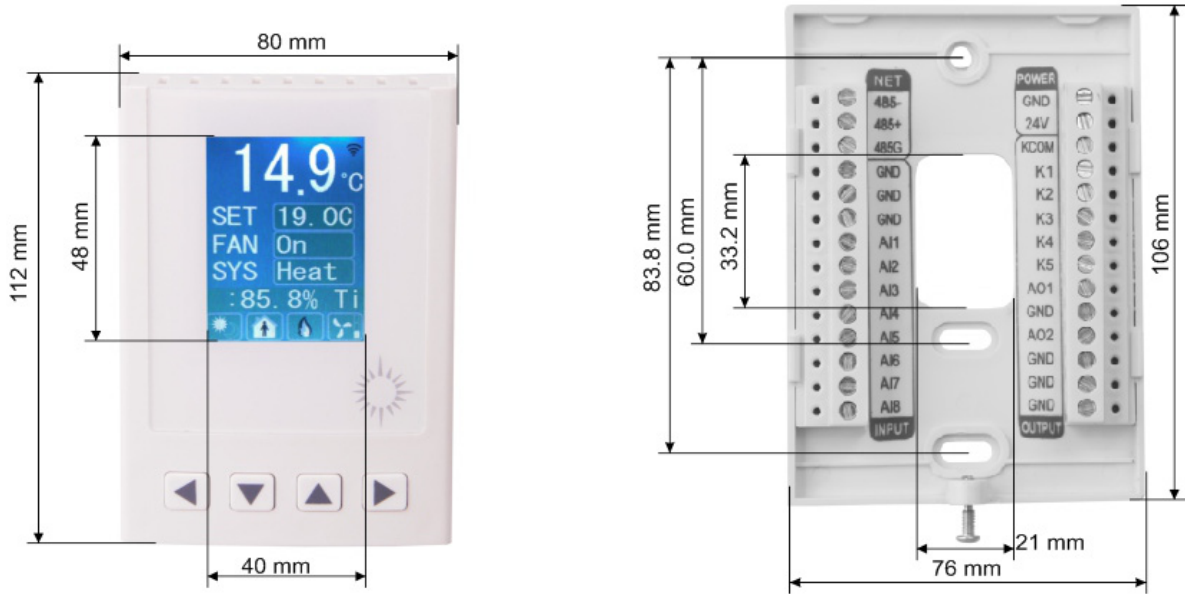

# Wiring Diagram

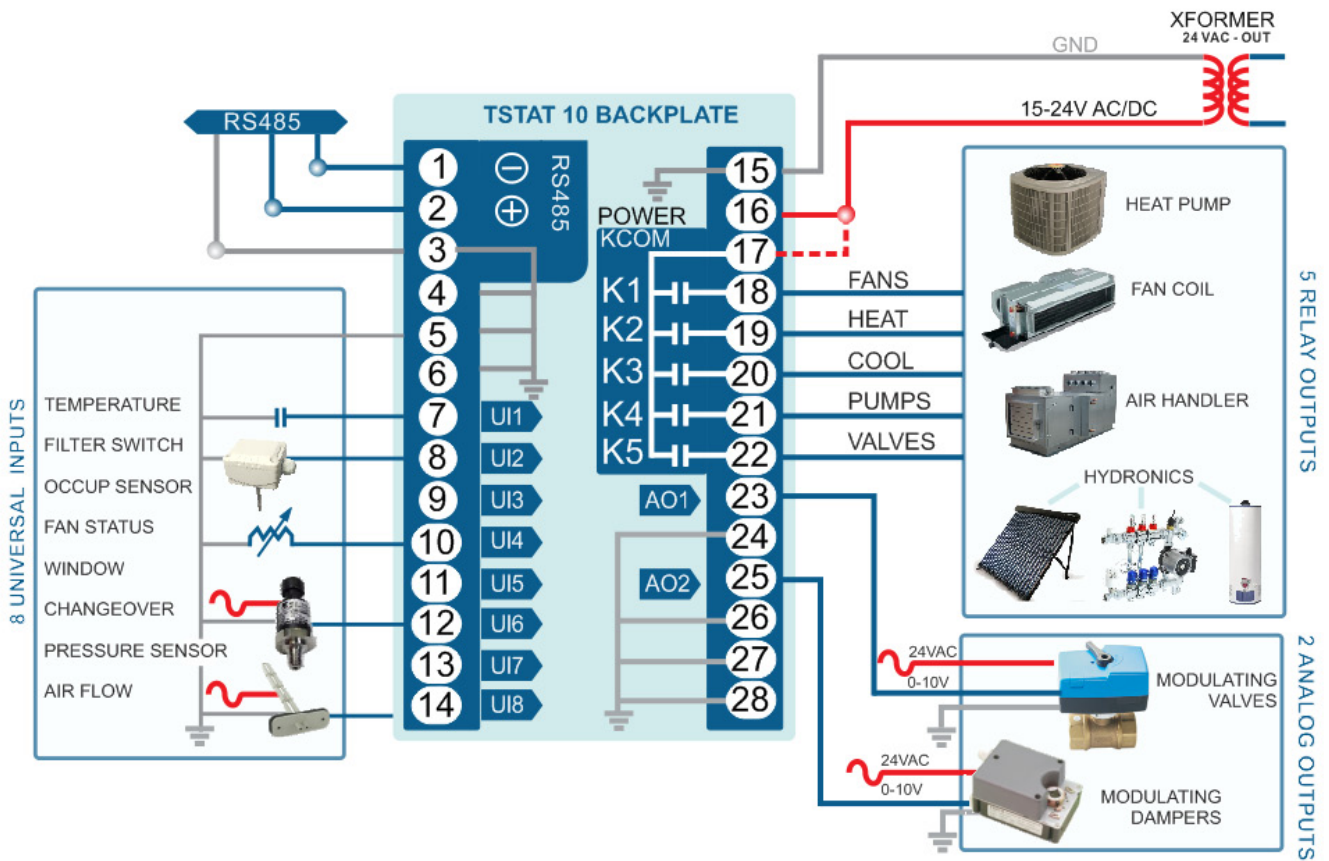

## Approvals

Relay	UL File No.: E169380
Plastic Enclosure	PA66 UL 94 V0 file E56070
PCB	FR-4 Epoxy Glass Cloth UL E479892
Terminal Block	PA66 UL 94V-0

## Software

8 analog inputs, 2 analog outputs; 5 digital outputs
Industry standard Bacnet & Modbus protocols
User screen displays
Day at home, work time, night at home, sleep, holiday

## Bacnet Objects

Device	Object identifier; Object name; Object type; Vendor name; Vendor identifier; Model name; Firmware revision; Application software version; Protocol version; Protocol revision; Object list; Max apdu length accepted; Segmentation supported
Analog input	Object identifier; Object name; Description; Object type; Present value; Out of service; Units
Analog output	Object identifier; Object name; Description; Object type; Present value; Out of service; Units; Priority array
Analog value	Object identifier; Object name; Description; Object type; Present value; Out of service; Units; Priority array
Binary output	Object identifier; Object name; Description; Object type; Present value; Out of service; Units; Priority array; Polarity; Relinquish default; Active text; Inactive text

## Part Number Scheme

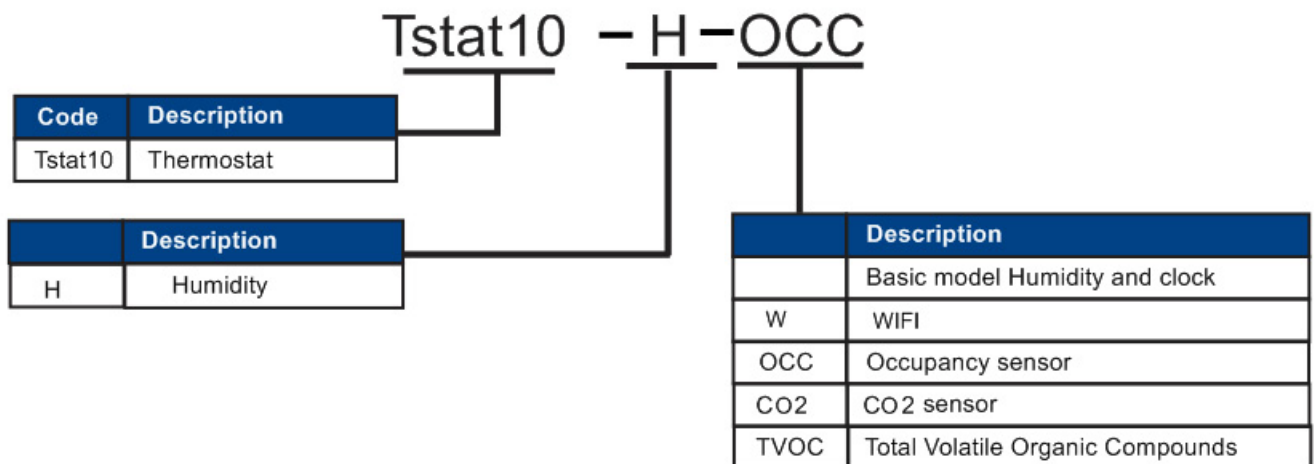

## Highlights

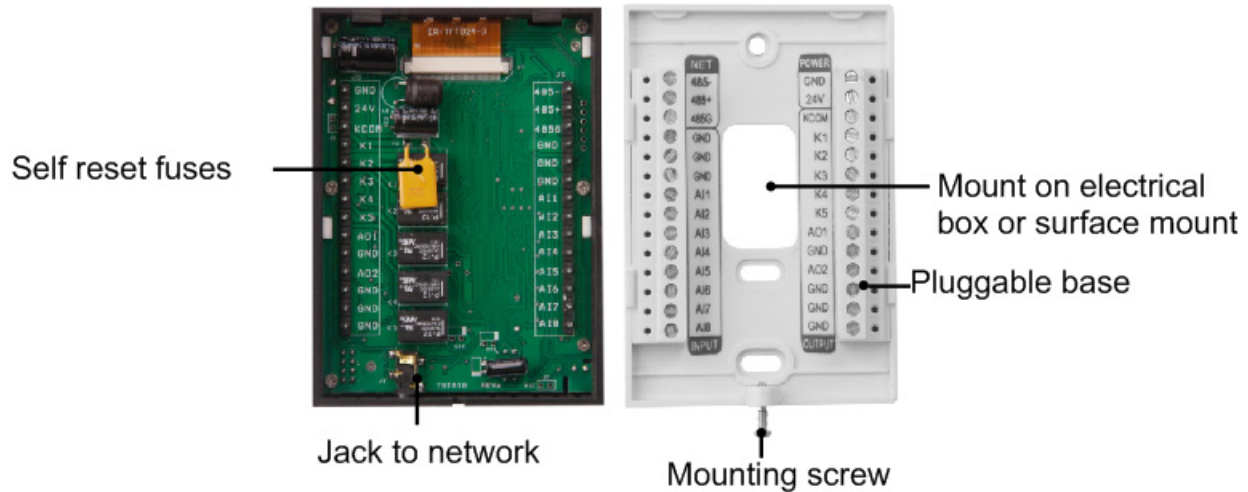

## Advanced Menu Item Details

They have several advanced menu items which can be adjusted in the field to suit the application and tune the operation of the thermostat. Generally speaking, all the parameters are set up at the factory on an order-by-order basis and will give satisfactory results out of the box.

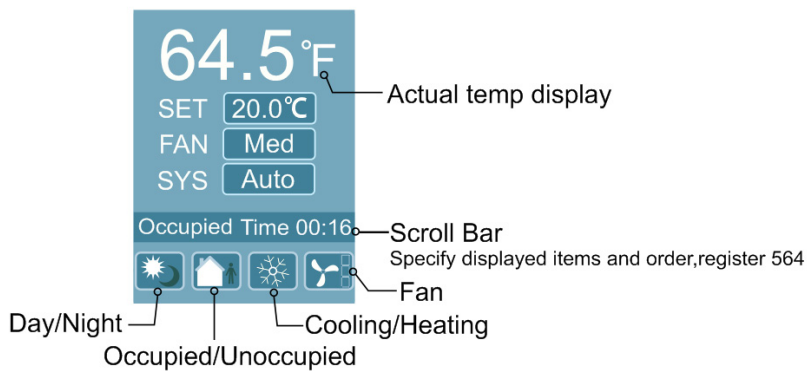

# Programs

- Hot Key: Alt-P
- KEYWORD: PRG
- Usage:PRG1,PRG2,PRG3...How to show: when you use one of these items , the label of the item will be shown in the place where you use
- Control Basic is the programming language of the T3000. To access an individual program pressthe “Ins” key while high lighting that program. The programming language is discussed in Chapter 10
- Sample Control Basic work screen:

	1 Full Label	2 Status	3 Auto/Manual	4 Size	5 Run Status	6 Label
<input checked="" type="checkbox"/> 1	AHU1 PROGRAM	ON	Auto	15	Normal	AHU1P
<input type="checkbox"/> 2	PRG2	OFF	Auto	50	Normal	AHU2P
<input type="checkbox"/> 3		OFF	Auto	0	Normal	AHU3P
<input type="checkbox"/> 4		OFF	Auto	0	Normal	BP
<input type="checkbox"/> 5		OFF	Auto	0	Normal	CHP
<input type="checkbox"/> 6		OFF	Auto	0	Normal	
<input type="checkbox"/> 7		OFF	Auto	0	Normal	
<input type="checkbox"/> 8		OFF	Auto	0	Normal	
<input type="checkbox"/> 9		ON	Auto	0	Normal	
<input type="checkbox"/> 10		ON	Auto	0	Normal	
<input type="checkbox"/> 11		ON	Auto	0	Normal	
<input type="checkbox"/> 12		ON	Auto	0	Normal	
<input type="checkbox"/> 13		ON	Auto	0	Normal	
<input type="checkbox"/> 14		ON	Auto	0	Normal	
<input type="checkbox"/> 15		ON	Auto	0	Normal	
<input type="checkbox"/> 16	COUNT	ON	Auto	36	Normal	

Control Basic set-up fields:

Full Label

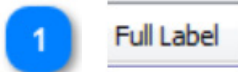

A 20 character descriptor of

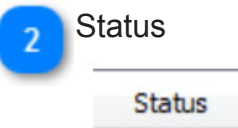

Indicates whether the program is running or not (ON/OFF).

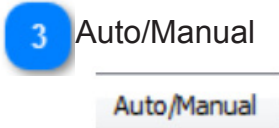

In “Auto” the running of the program can be controlled by either the program timer or another program. In “Manual” the program can be stopped and started by the operator by toggling the status field.

4

### Size

Size

The length in bytes of the program, maximum size is 2500 bytes.

5

### Run Status

Run Status

The time between each running of the program (mins: secs).

6

### Label

Label

An 8 character descriptor of the point. See Chapter 10 for more information on how to program Control Basic and use the Control BasicEditor

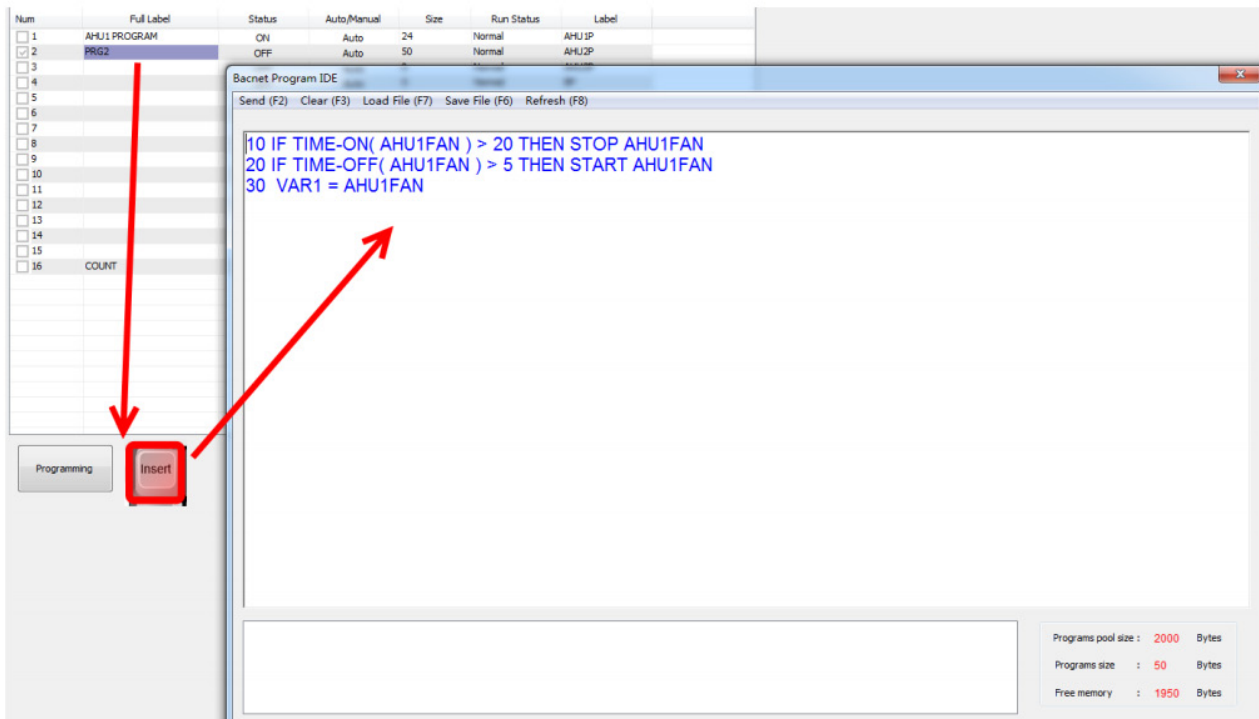

## Register List

Address	R/W	Length	Description
0~3	R	4	Reserved for serial numblert
4~5	R	2	firmware Version Number
6	R/W	1	Modbus device address
7	R	1	Prodouct model
8	R	1	Hardware Version Number
9	R	1	PIC rev
12	R	1	UART0 Baudrate. 5 - 9600 , 6 - 19200
14	R	1	ISP Version
18	R/W	1	UART1 Baudrate. 5 - 9600 , 6 - 19200
19	R/W	1	UART2 Baudrate.(UART_1200 = 0, UART_2400 = 1, UART_3600 = 2, UART_4800 = 3, UART_7200 = 4, UART_9600 = 5, UART_19200 = 6, UART_38400 = 7, UART_57600 = 8, UART_115200 = 9, UART_921600 = 10
33	N	1	test cmd, write 77 - reboot, 100 - set default paramer, 111 - erase prg, 150 - clear tstat db
34	R	1	board type, big or small. 1 - big , 2 - samll,3-tiny,4-vav
35	R	1	instance number
36	R	1	station number
39	R/W	1	EN clear tstat db
42	R/W	1	USB MODE
43	R/W	1	EN DYNDNS ,// 0 - no 1 - disable 2 - enable
44	R/W	1	DYNDNS provider, // 0- www.3322.org 1-www.dyndns.com 2 - www.no-ip.com
45	R/W	1	dyndns update timer
46	R/W	1	NETWORK: MSB, MSB-1
47	R/W	1	MSTP NETWORK: MSB, MSB-1
51	R	1	TOP hardware
52	R	1	c8051f023 firmware rev
53	R	1	sm5964 firmware rev
...			

## Tstat10-Wifi Set Up

### Configuration Setting

To set the password and IP address of the Tstat10, two methods are available:Key setting and Adhoc setting or using the T3000 software Key setting.

First install this app in a android phoneAnd connect your phone with your wifi router,power on Tstat10.

The app will get the SSID from your phone and you need enter the wifi password, click confirm buton then app will send a broadcast message through wifi router to Tstat10

Visit <https://temcocontrols.com/ftp/software/24esptouch.zip>, download Androidwifisetup software and install it;



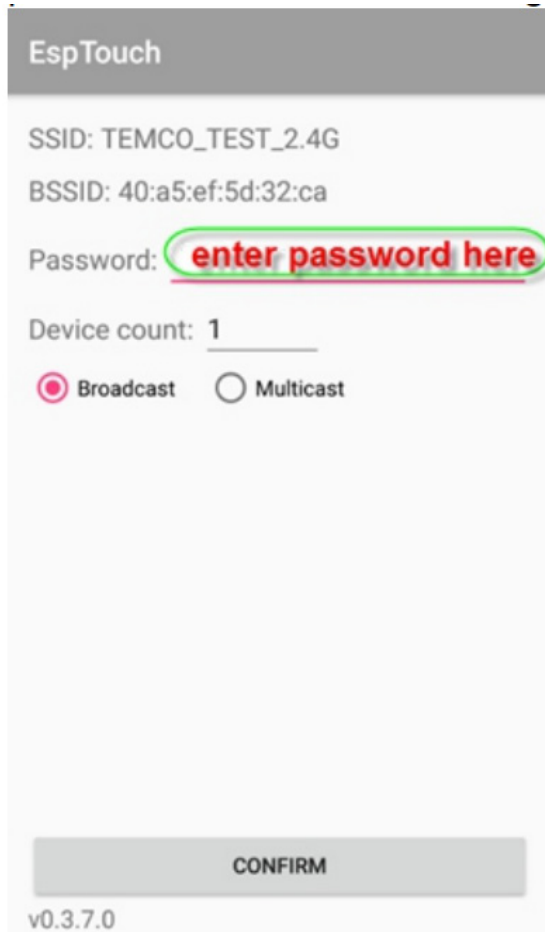

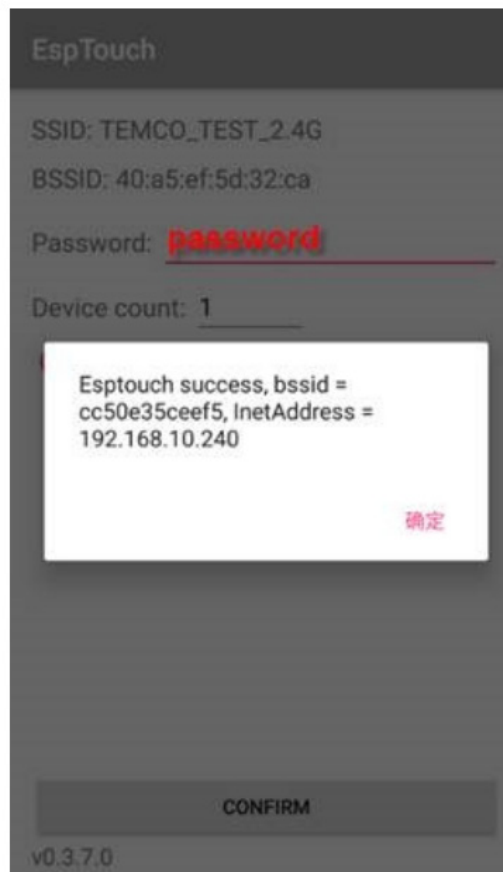

After about less than 20 seconds, Tstat10 will get the IP, and can see the message from phone

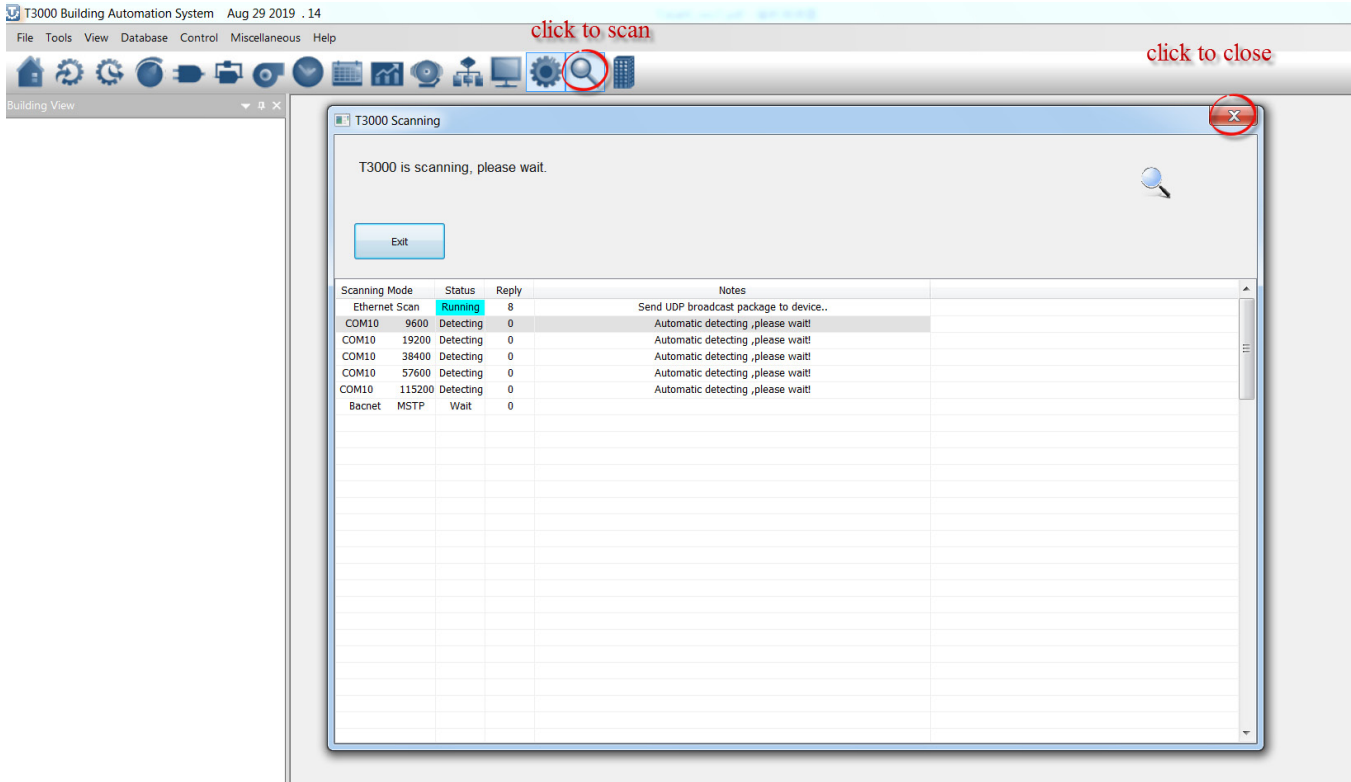

# T3000 Operation

1. Connect Tstat10 to PC by RS485, start T3000 software



2. Click the button  to scan, the following view will appear and close it as the picture indicates. When discussing Tstat10, close the view.

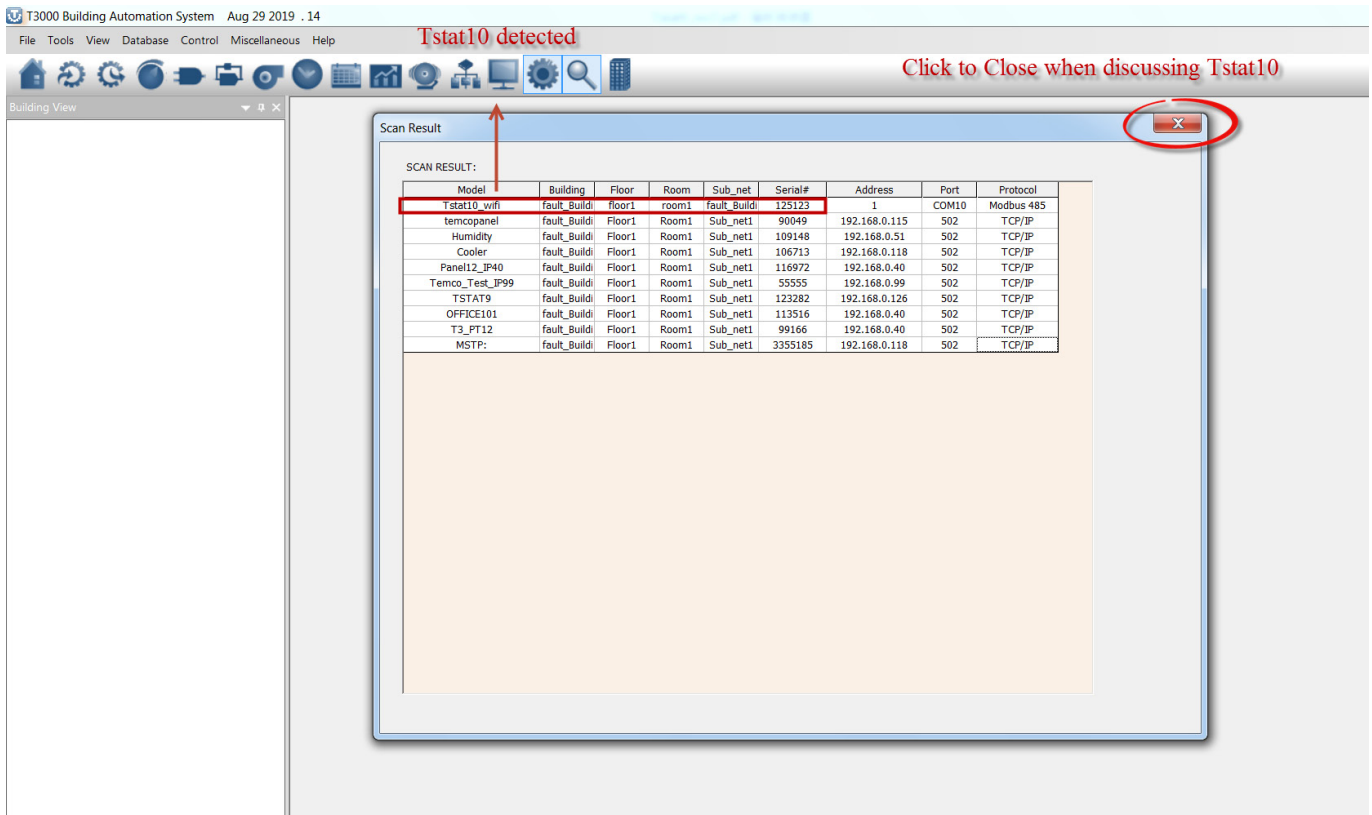

### 3. Get Tstat10-wifi information to T3000

The screenshot displays the T3000 Building Automation System interface. The main window is titled "Setting" and has tabs for "Basic information", "TCP/IP", "Time", "DynDNS", "Email", "User Login", and "Expansion IO". The "TCP/IP" tab is selected. In the left-hand "Building View" pane, the "Local Network" section is expanded, showing various devices, with "Tstat10\_wifi" highlighted in red. Below this pane, the text "Tstat10-wifi Log" is written in red. In the "TCP/IP" tab, the "IP Address" section shows "Obtain IP Address Automatically" selected. Below this, the "Wifi Configuration" button is circled in red, with the text "Click to do settings" written below it. A "Wifi Setting" dialog box is open on the right, titled "Wifi Setting". It contains the text "Customer device id and key" in red. The "Network Type:" dropdown is set to "WIFI". The "SSID:" field contains "TPLINK-SSID\_TEST" and the "Key:" field contains "12354645645", both circled in red. The "Obtain an IP address automatically" radio button is selected. Below the IP settings, the "Apply" button is circled in red, with the text "Click to apply" written below it.

Building View

Default\_Building

- Local Network
  - Cooler
    - MSTP:
  - Humidity
  - Panel12\_IP40
    - OFFICE101
    - T3\_PT12
  - Temco\_Test\_IP99
  - temcopanel
  - TSTAT9
- Serial Port
  - Com10
    - Tstat10\_wifi
- Virtual Device

Tstat10-wifi Log

Setting

Basic information TCP/IP Time DynDNS Email User Login Expansion IO

IP Address

Obtain IP Address Automatically

Use The Following IP Address

IP Address : 255 . 255 . 255 . 255

Subnet Mask : 255 . 255 . 255 . 255

Gateway Address : 255 . 255 . 255 . 255

Wifi Configuration Change IP

Click to do settings

Wifi Setting

Customer device id and key

Network Type: [WIFI]

SSID: [TPLINK-SSID\_TEST]

Key: [12354645645]

Obtain an IP address automatically

Use the following IP address

IP: 192 . 168 . 0 . 11

Subnet: 255 . 255 . 255 . 0

Gateway: 192 . 168 . 0 . 1

MAC: 01-00-01-00-01-00

Apply Exit

Click to apply