

3 Phase Power meter

Descriptions

The instrument is to measure any range of AC/DC voltage or current set by user. It can be available for data reserve or top value reserve function. To measure or display true value of voltage/ampere/watt/power factor/frequency/energy consumption. Up to 3 alarm output. This instrument is widely applied to power system, factory power distribution, building automation etc. With RS485 for remote control.



Highlights

1. Input: true value single/three phase measure (bandwidth : up to 2.5KHz) more than 32 parameters, such as AC DC voltage/ampere/power/power factor/frequency/electrical degree/reactive power/power frequency, etc, mini power is 1mW, apply to energy-saving equipment, motor, lab, production line for electrical parameters integrated measurement.
2. Features: voltage/ampere ratio set freely, input isolation among phases, single/three phase three-wire three- factors, three-phase three wire two factors, three phase four-wire selectable;
3. Output: 3-line alarm output configurable, up to 8 segment output control, parameters: under-voltage/ under-ampere/over voltage/over ampere/power/power factors selectable, analog output 4-20mA;
4. RS485 interface, MODBUS RTU protocol, connect directly to various equipment, computer and PLC;
5. Widescope power supply: regular: 80-265V AC/DC, 12-30V indicate when ordering;
6. case class: IP65;
7. Widely used in automatic control of power system, factory power distribution, building automation, eg., single/three phase, voltage/current/power, three phase voltage/ampere integrated display control or up to 6 lines voltage/ampere display control; and power factor compensation control.

3 Phase Power meter

Specifications

Power supply	90-260V AC/DC 50/60Hz
Measured objects	True value, simple/three phases/voltage/current/Watt/Power factor/frequency/energy consumption/reactive power
Direct input range	Voltage:0-600V Current:0-5A
P/T,C/T	P/T,C/T free set by software
Measured frequency range	0-400Hz
Accuracy	Voltage: $\pm 0.2\% \pm 0.1\% \text{F.S}$ Current: $\pm 0.2\% \pm 0.1\% \text{F.S}$ Watt: $\pm 0.3\% \pm 0.2\% \text{F.S}$ Power factor: ± 0.01 Frequency: Display 0-400Hz $\pm 1\text{Hz}$
Analog	0-10V or 4-20mA selectable by software
Alarm	RELAY:NO 250V AC 3A or 30V DC 3A COS $\varnothing=1$
Communication	RS232 or RS485 with MODBUS RTU protocol

Dimensions

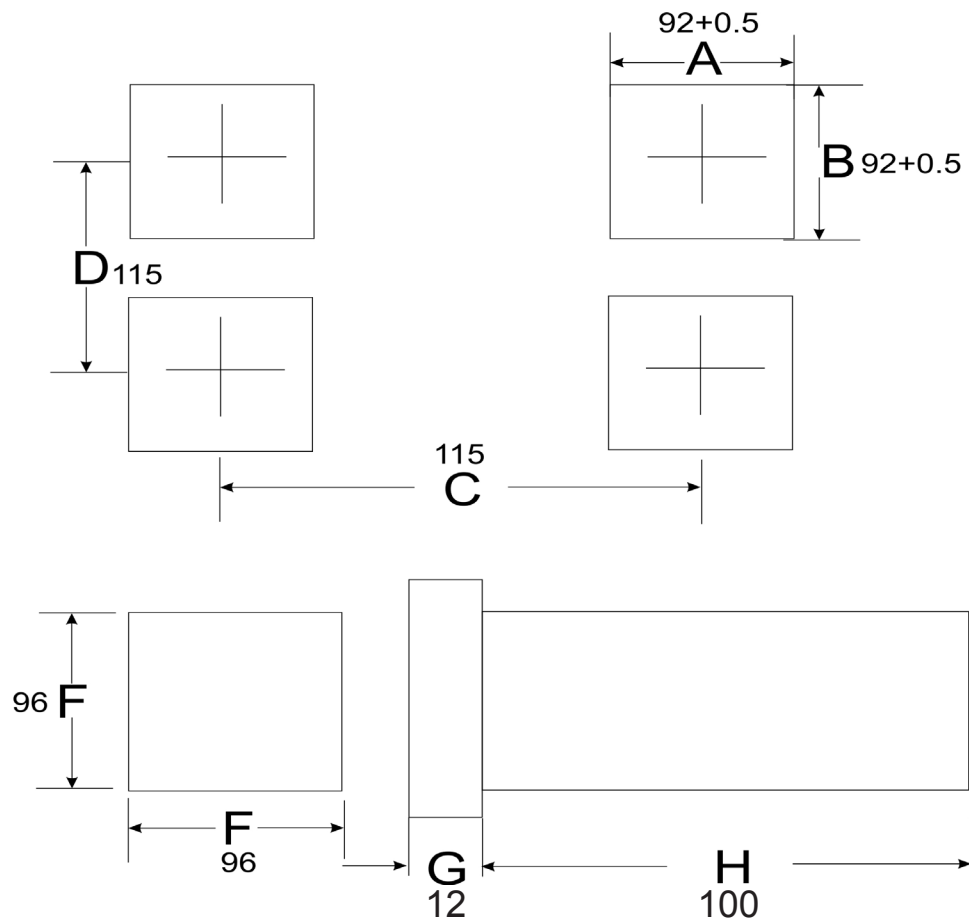

Wiring Diagrams

1.Simple phase connections(3 phase 4 wires simple connection,without PT,without CT)

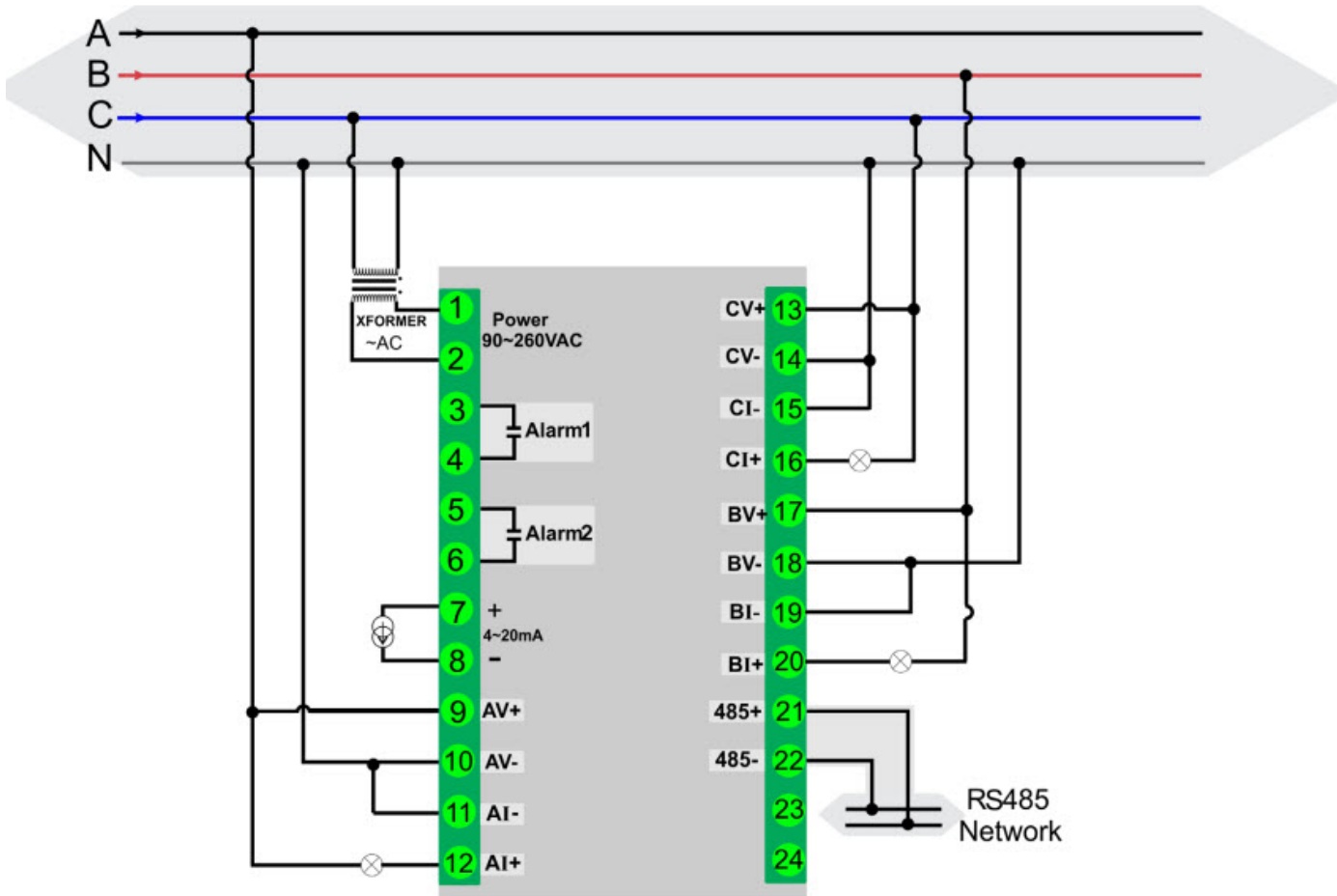

Note:

Values are 8 digit LED display in total,each 4 in UP and DOWN.Normally displays DOWN 4 digits. Press the lamp flashes,then display the UP values.

2.3 phase 4 wires without P/T,CT connections:

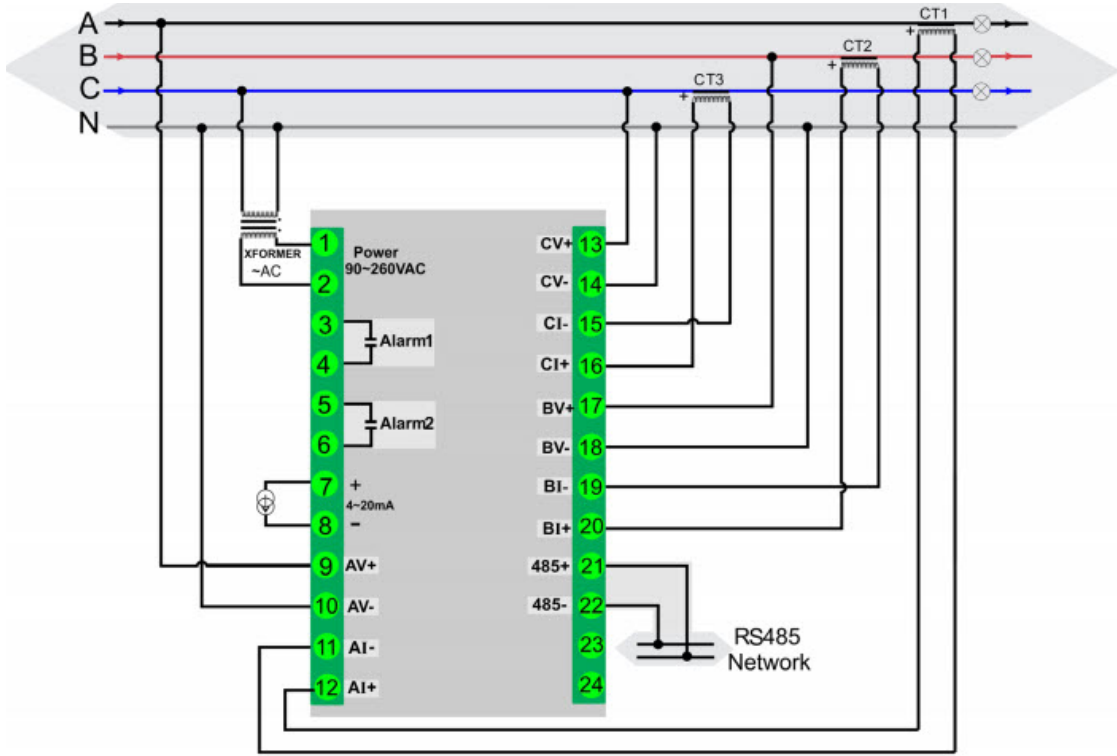

with P/T,CT connections:

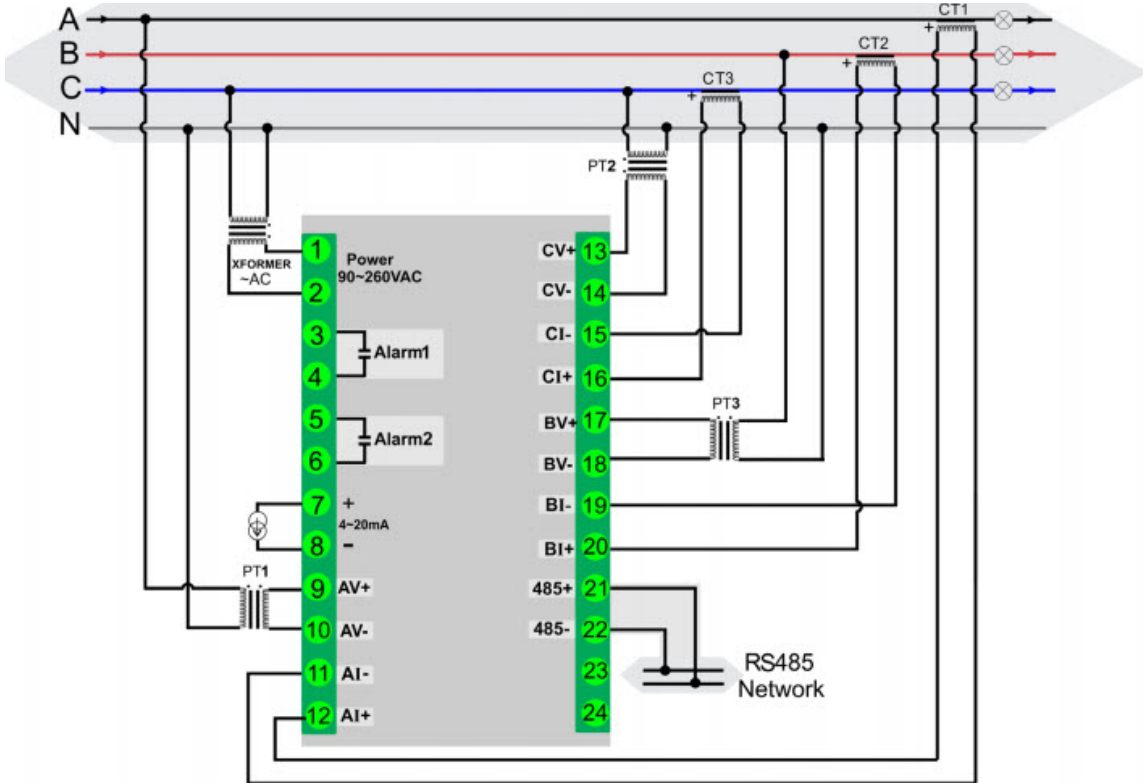

3 Phase Power meter

3.3 phase 3 wires(power for A/B phase,c phase for display only,without PT)

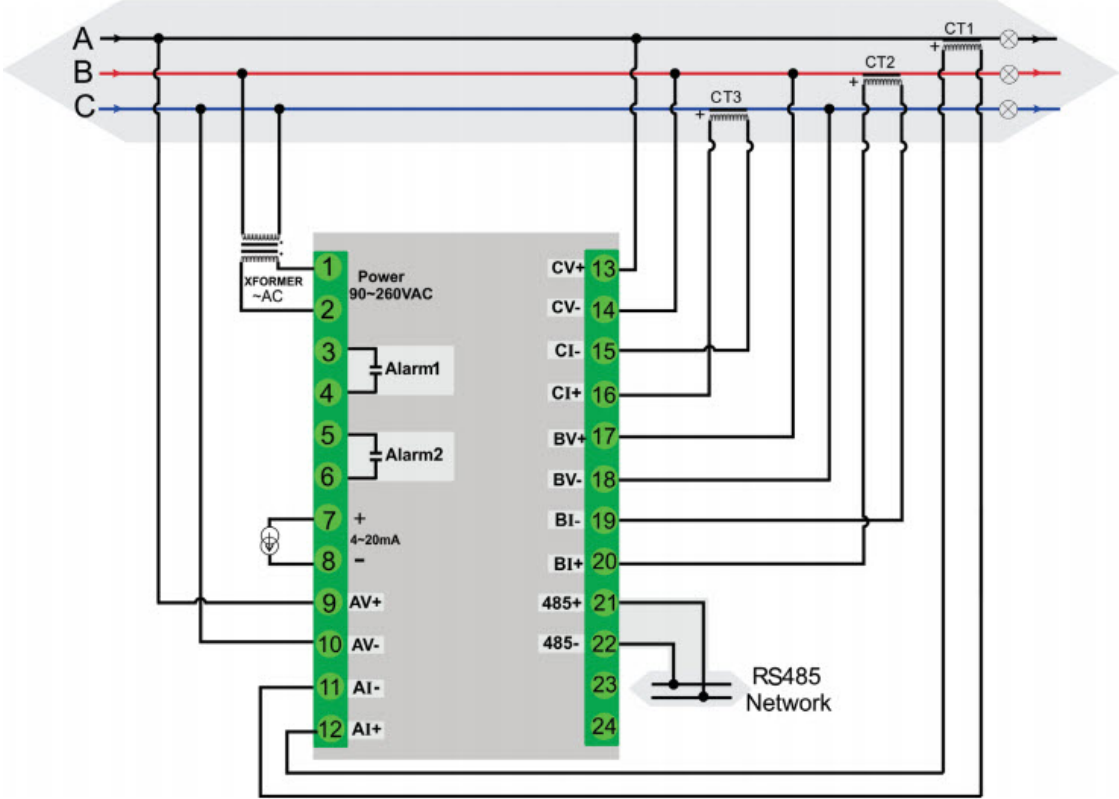

Notes:

When there is no transformer, please connect vot/amphere in series directly, eg the connection of 3 phase 4 wires without P/T,C/T connections.

3 Phase Power meter

4.3 phase 3 wires 3 phase(A/B phase ,C phase for display only,with PT)

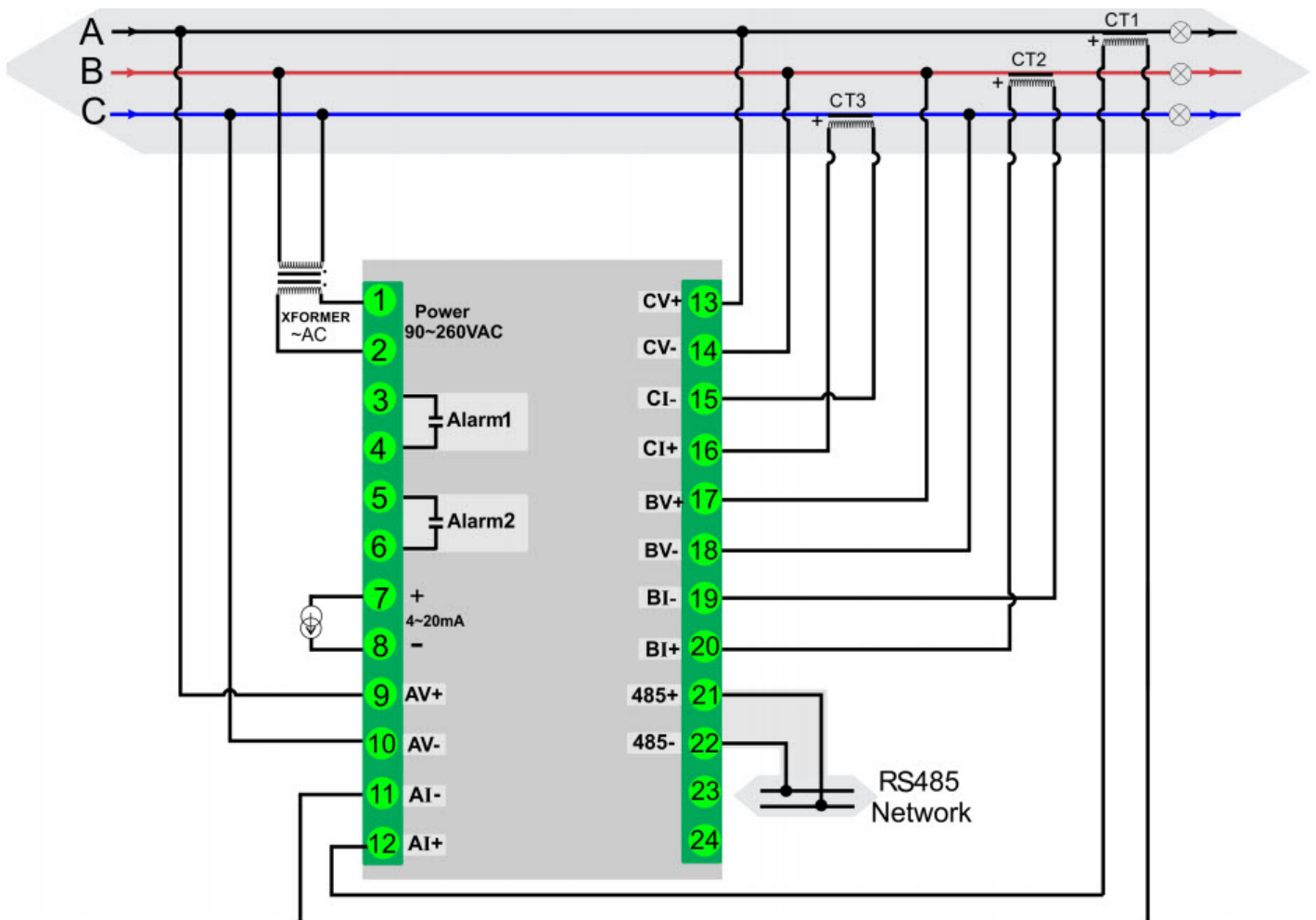

Malfunction Estimate:

1. Check the connection and wiring if correct. Specially pay attention to the power supply terminals and signal input terminals, please do not connect wrong. As well pay attention to do not short the output terminals by strong current.
2. If the measurement is incorrect, please check if the connection is contrary □ □ □
3. Check input mode setting, especially 3 phase connection. The parameter is

Name of parts

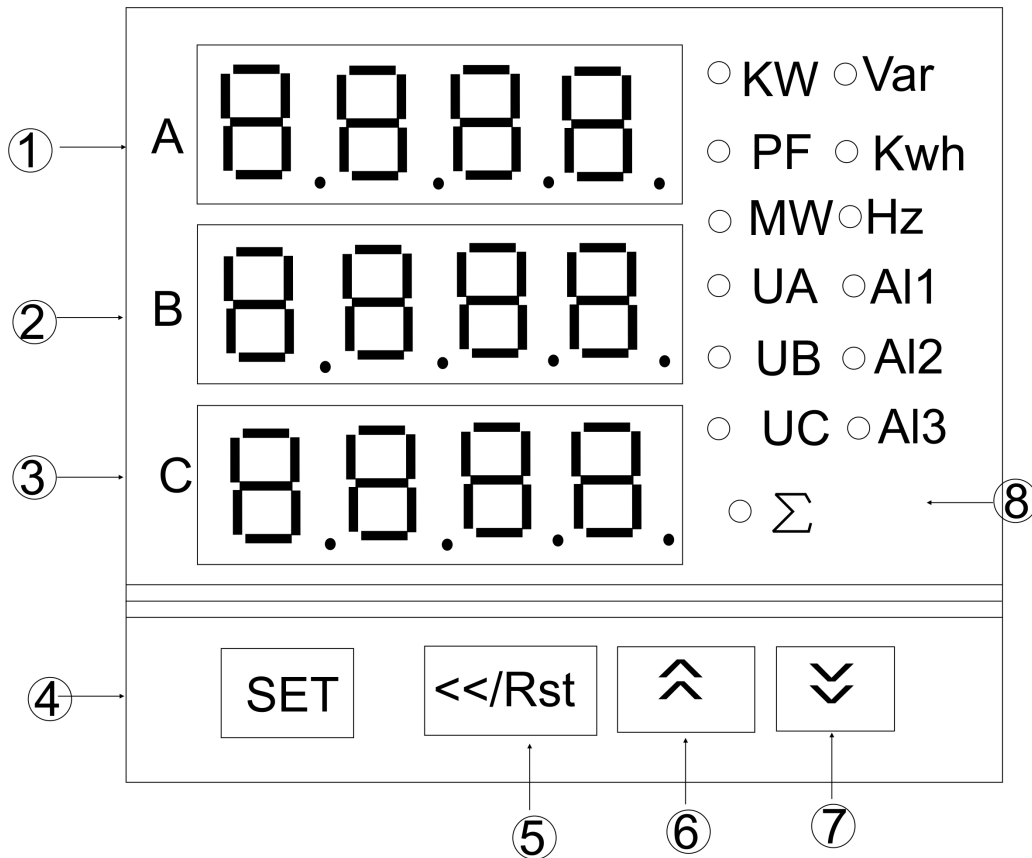

- ① 3 phase KW/Var/PF/Kwh/MW/Hz display window
 - ② phase voltage measured value/parameter display window
 - ③ 3 phase current measured value/parameter modified display window
 - ④ Convert/Set/Confirm key
 - ⑤ Shift/Clear key
 - ⑥ ⑦ Up key/Down key
 - ⑧ indication lamps
- Hz:frequency unit
 MW:3 phase A/B/C/Σ watt
 KW:3 phase A/B/C/Σ watt
 PF:Var:3 phase A/B/C/Σ watt power factor
 Var:3 phase A/B/C/Σ watt VAR
 Kwh3 phase A/B/C/Σ watt energy consumption
 Inactive power displays when Var&Kwh lamps on at the same time UA/UB/UCღş Phase A/B/C/Σ running value
 Σ:Aummmation of the phase
 AI1/AL2/AL3:Alarm1/@/3
 On:output Off:No alarm

Notes:

The instrument can measure both simple phase and 3 phase. Factory setting is 600V,5A AC,P/T rate free set by software. Measure AC voltage more than 600V, please use the instrument with C/T. Measure AC current more than 5A, please use the instrument with P/T. Three phase different voltage/current input need.

Parameter setting

1. In the measuring estate, press and hold SET key for more than 3 seconds, enter control parameter setting menu. Press <</RST key, LED flashes, press \approx/\cong key to modify, and then press SET key to confirm. Press SET key to read the following parameters one by one.
2. The instrument will return to the measuring estate without any operation for 25 seconds.
3. Convert display (Frequency input is displayed in A phase only and voltage > 80V).
 - A. Window A is mainly used to display KW/VAR/PF/Kwh of one of phase A/B/C/UC will show the present selected phase or summation. Press SET key can convert displaying KW/VAR/PF/Kwh.
 - B. Window B is mainly used to display voltage of phase A/B/C, indicated by UA/UB/UC lamps.
 - C. Window B is mainly used to display current of phase A/B/C, indicated by UA/UB/UC lamps.
4. Kwh value clear. Press SET key, and let the indication lamp Kwh is on, press <</CLR key to select the phase that you want to clear UA/UB/UC, then press <</CLR key for two seconds till the window A display "0" or "0.000"
5. Power fail protection. Only for phase total Kwh value.
6. Window A power on display value setting: Set by the parameter "DIS"

Operation process

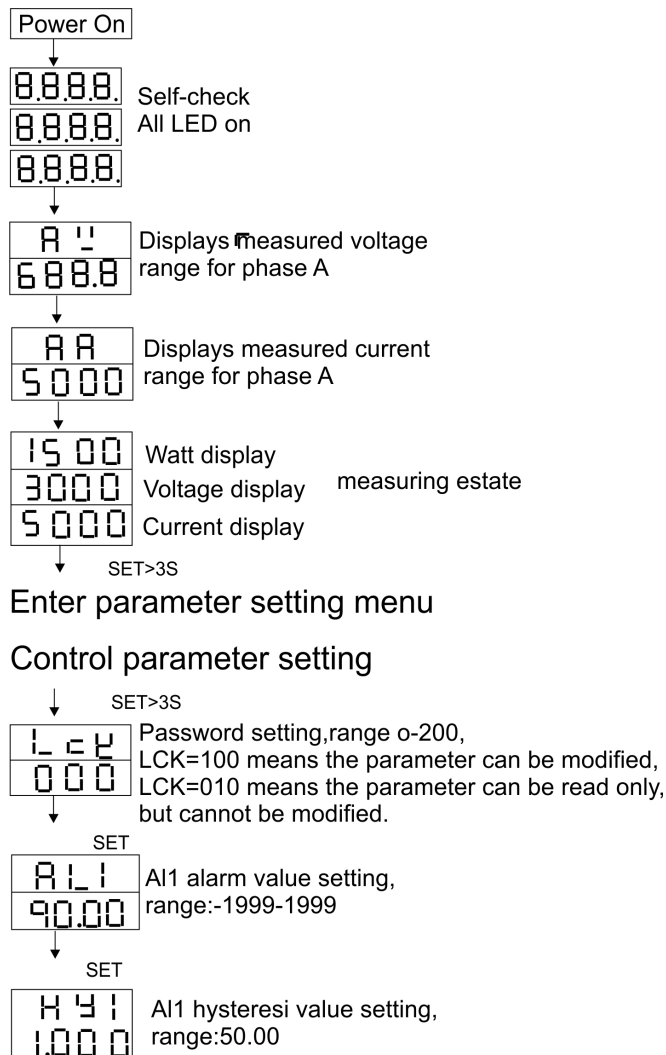

3 Phase Power meter

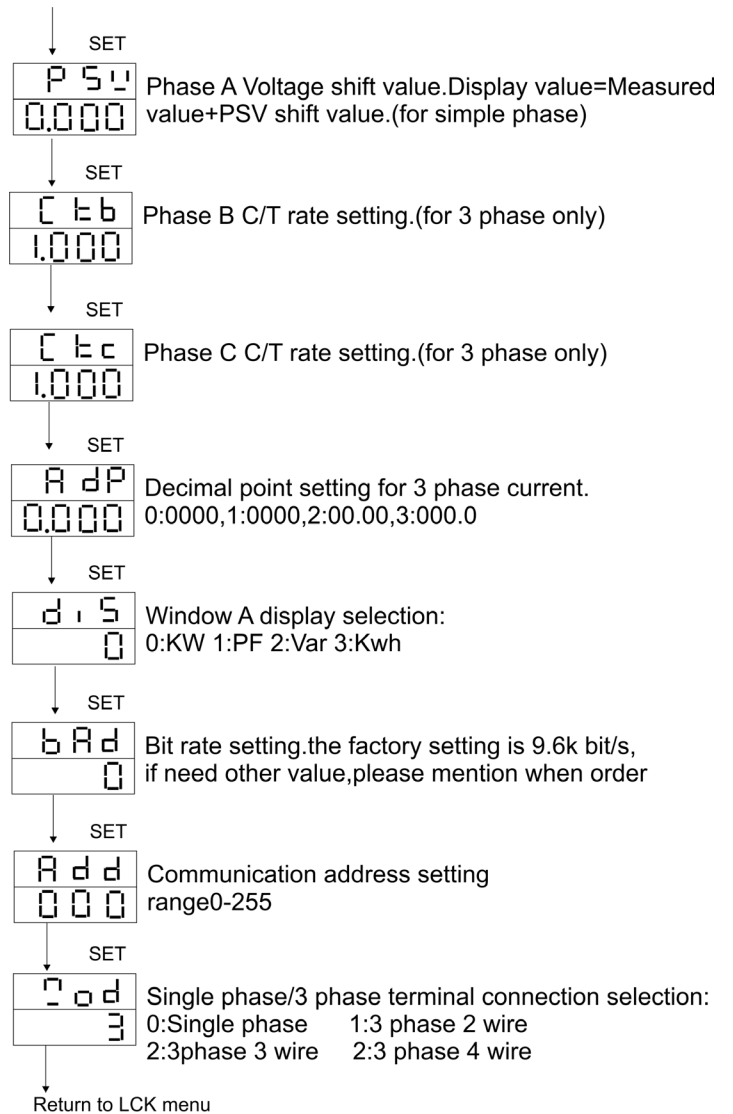
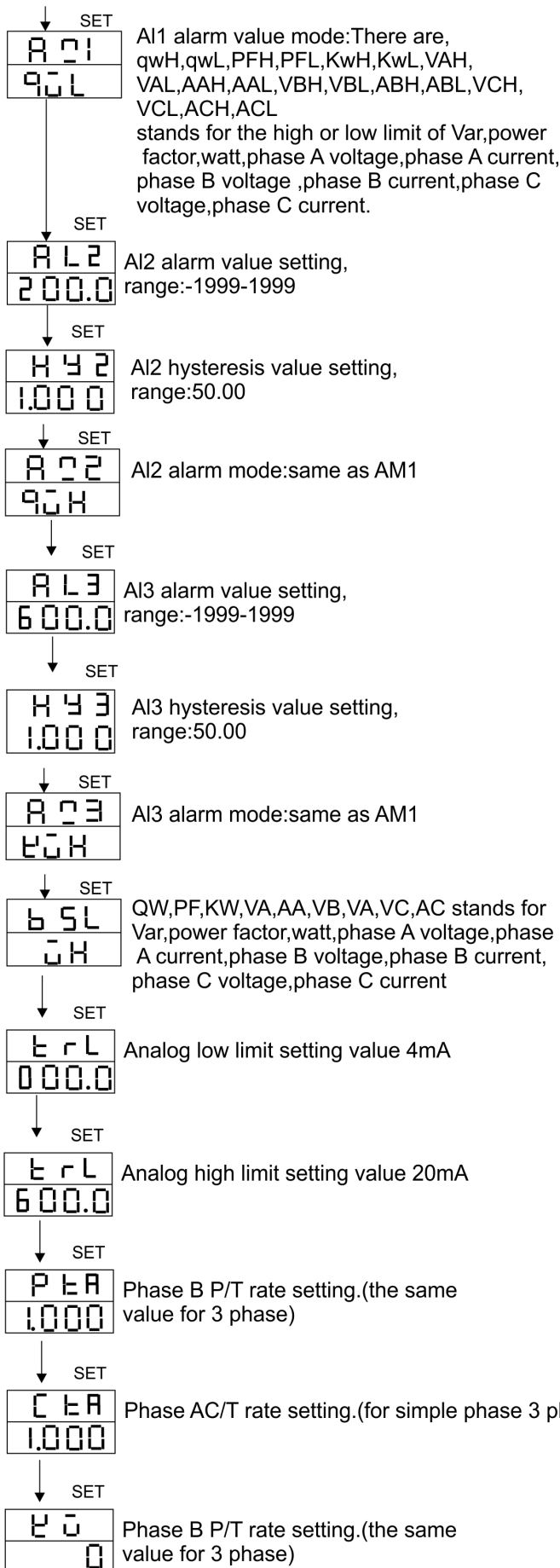

The parameters showed are factory setting

3 Phase Power meter

Warning

Please do not turn the power supply until all of the wiring is completed. Otherwise electrical shock, fire or malfunction may result.

Do not wire when the power is on.

Do not connect the unused terminals

Do not turn on the power supply when cleaning this instrument.

Do not disassemble, repair or modify the instrument. This may cause electrical shock, fire or malfunction.

Use this instrument in the scope of its specifications.

Otherwise fire or malfunction may result.

The use life of the output relay is quite different according to its capacity and conditions. If use out of its scope, fire or malfunction may result.

Caution

This instrument should be installed in a domestic environment. Otherwise electrical shock, fire or malfunction may result. The operating temperature environment should be between 0(32F) to 50(122F).

To avoid using this instrument in environment full of dust or caustic gas.

To avoid using this instrument in environment of strong shock or concussion.

To avoid using this instrument in environment of overflow water or explosive oil.

In case the instrument is used in environment of nuclear control, medical equipment, auto, train, airplane or security equipment that need protections, please contact the manufacturer for details.

When it's for 8 digitals coloumeter, it displays in 2 windows 4 digitats each. B window displays the high 4 digits, and C the low 4 digits. Unit: WH/KWH available for user's choice

3 Phase Power meter

Power Meter Modbus User Instructions

1, The instrument RS485 communication BPS is fixed at 9600 bits/s, start bit=1, data bit =8, stop bit=1, starting and ending time>5ms.

2, The format of the data reading and writing is same as standard Modbus protocol. Definition as follows:

Request:(eg:send order to read AI current,01 03 00 B9 00 02 15 EE)

01	03	0185(00B9H)	0002	(15EE)
ADD	COM	PV1	Counts	CRC

Response:(eg:01 03 04 6D 96 49 F3 71 66)

01	03	04	6D96 49F3	7166
ADD	COM	Counts	PV1	CRC

Return Power:2 WORD

PV1=6D96 49F3=6D96.49F3H=INT 6D96H+POINT 49F#H=28054+18931/65536=28054.2888(49F3H=18931 6D96H=28054)

When Max bits is 1, means negative, viz. sign bit.

Ed96 bit 15=1 is negative, viz. -6D96H

3, When setting parameters, can read multi-parameters: when writing, can write 1 parameter only every time

4, Commands:

02H: read digital value/discrete I/O parameters

03H: read holding registers parameters

06H: write single holding register parameter value

10H: write multi holding registers parameters value

DW9 meter reading and writing parameter

Parameters address	Parameter type	COUNT numbers	Function	Remark
B4H(0180)	\sum PF	2	3phase power factor	Read only
B7H(0183)	\sum KW	2	3phase power	Read only
BAH(0186)	\sum Q	2	3phase reactive power meter	Read only
BEH(0190)	\sum KWH	2	3phase degree	R/W
55H(085)	\sum QWH	2	3phase total inactive power	R/W
C2H(0194)	A-V	2	A phase voltage	Read only
C5H(0197)	A-I	2	A phase current	Read only
C8H(0200)	A-PF	2	A phase Power factor	Read only
CBH(0203)	A-KW	2	A phase power	Read only
CEH(0206)	A-VAR	2	A phase power rective power	Read only
D2H(0210)	A-KWH	2	A phase degree	Read only
D6H(0214)	B-V	2	B phase voltage	Read only
D9H(0217)	B-I	2	B phase current	Read only
DCH(0220)	B-PF	2	B phase power factor	Read only

3 Phase Power meter

DFH(0223)	B-KW	2	B phase power	Read only
E2H(0226)	B-VAR	2	B phase rective power	Read only
E6H(0230)	B-KWH	2	B phase degree	Read only
EAH(0234)	C-V	2	C phase voltage	Read only
EDH(0237)	C-I	2	C phase current	Read only
F0H(0240)	C-PF	2	C phase power factor	Read only
F3H(0243)	C-KW	2	C phase power	Read only
F6H(0246)	C-VAR	2	C phase rective power	Read only
FAH(0250)	C-KWH	2	C phase degree	Read only
03H(0003)	Add	1	Communication address	R/W
04H(0004)	AL1	2	AL1 alarm value	R/W
08H(0008)	HY1	2	deviation alarm setting	R/W
0BH(0011)	AM1	1	Alarm mode	R/W
0CH(0012)	AL2	2	Alarm 2 value	R/W
10H(0016)	HY2	2	AL2 deviation alarm setting	R/W
13H(0019)	AM2	1	AL2 Alarm mode	R/W
14H(0020)	AL3	2	Alarm 3 value AL3	R/W
18H(0024)	HY3	2	AL3 deviation alarm setting	R/W
1BH(0027)	AM3	1	AL3 Alarm mode	R/W
1CH(0028)	BSL	2	Current output parameter setting	R/W
20H(0032)	BRL	2	Current output low limit setting	R/W
24H(0036)	BRH	2	Current output high limit setting	R/W
28H(0040)	PTA	2	3 phase voltage PT ratio setting	R/W
2CH(0044)	CTA	2	A phase current CT ratio setting	R/W
38H(0056)	CTB	2	B phase current CT ratio setting	R/W
3CH(0060)	CTC	2	C phase current CT ratio setting	R/W
3FH(0063)	ADP	1	Decimal point of current display setting	R/W
40H(0064)	DIS	1	Parameter display setting when power on	R/W
43H(0067)	LIN	1	3 phase wire-connection type setting	R/W