

NO-Contact Liquid Level Sensor

Descriptions

The intelligent non-contact liquid level sensor (hereinafter referred to as the liquid level sensor) adopts advanced signal processing technology and high-speed signal processing chip, which breaks through the influence of container wall thickness and realizes a true non-contact type of liquid level height in a closed container Detection. The liquid level sensor (probe) is installed on the upper and lower sides of the outer wall of the container to be measured (the high and low levels of the liquid level). The non-metallic container does not need to be opened, and the installation is simple and does not affect production. It can detect the liquid level of various liquid toxic substances, strong acids, strong alkalis and various liquids in high-pressure airtight containers. The liquid level sensor has no special requirements for the material of the liquid medium and the container, and can be widely used. XKC-Y26-XXX series products are specially developed for non-metallic pipeline liquid level detection



Product Features

1. XKC-Y26-XXX non-contact liquid level sensor is suitable for all kinds of non-metal containers. The product detects the liquid through the detection signal through the non-metal container and the outer wall of the pipeline, without direct contact with the liquid. It is corroded by strong acids and alkalis and other corrosive liquids, and is not affected by scale or other debris, and it can be completed to detect whether there is liquid inside the container or pipeline.
2. Product design intelligent liquid level reference adjustment and liquid level memory function, liquid level status display mode, can realize multi-point series connection control mode. It can support high and low level output, NPN, PNP signal output control (please refer to the manufacturer's instructions when selecting the model).
3. The detection liquid level is accurate and stable, and cold, hot and boiling liquids can be detected.
4. Pure electronic circuit structure, non-mechanical working mode, stable performance and long lasting service life.
5. High stability, high sensitivity, strong anti-interference ability, free from external electromagnetic interference, special treatment for power frequency interference and common mode interference, to be compatible with all 5~24V power adapters on the market.
6. Wide range of application, strong sensing ability, can penetrate and detect the liquid level in various non-metallic containers and pipes, such as plastic, glass, ceramics and other containers. The thickness of the sensing pipe wall can reach 20mm; it can be applied to various curved surfaces. , Arc, cylindrical and other irregular containers or pipeline liquid level detection.
7. Wide voltage range (5~24V), suitable for connecting various circuits and product applications

Product Applications

The intelligent non-contact liquid level sensor uses the inductive capacitance of water to detect the presence of liquid. When there is no liquid close to the sensor, the sensor has a certain static capacitance to the ground due to the presence of distributed capacitance on the sensor. When the liquid level is slow When the sensor is slowly raised, the parasitic

capacitance of the liquid will be coupled to the static capacitance of the sensor, making the capacitance value of the sensor larger. The changed capacitance signal is then input to the control IC for signal conversion, and the changed capacitance is converted into a circuit signal. When the amount of change exceeds a certain threshold, it is judged that the liquid level has reached the sensing point.

Product parameter

Project name	Parameters	
Product model		
Supply voltage (Vin)		
Output mode		
electric current		
The output voltage (high pulse)		
The output voltage (low pulse)		
The output current		
Response time		
Working temperature		
Sensor sensitivity	Outer diameter of pipe D(mm)Sense container wall or tube wall thickness L(mm)	
	Outer diameter of pipe D(mm)	Sense container wall or tube wall thickness L(mm)
	D≥100	20 ± 2
	100>D≥80	15 ± 2
	80>D≥60	12 ± 1.5
	60>D≥40	7 ± 1.0
	40>D≥30	5 ± 1.0
	30>D≥20	3 ± 1.0
20>D≥10	1.5 ± 0.5	
Applicable pipe diameter range	≥10mm	
Liquid level accuracy	±1.5mm	
Humidity	5%~100%	
Material	PC V0 Fireproof material	
Waterproof performance	IP67	
Safety standard certification	CE	
Environmental protection certification	ROHS-2.0	

Product parameter

NPN output interface———Model: XKC-Y26-NPN (DC 5-12V)
 NPN output interface———Model: XKC-Y26-NPN (DC24V)

Clearance requirements

Requirements for the clearance between the contact surface of the sensor (or probe) and the outer wall of the container. The contact surface of the sensor (or probe) and the outer wall of the container should be tightly pasted with AB or other solid-resistant glue. If there are special requirements, the gap should be less than 0.5mm, preferably no gap, otherwise it may affect the measurement accuracy.

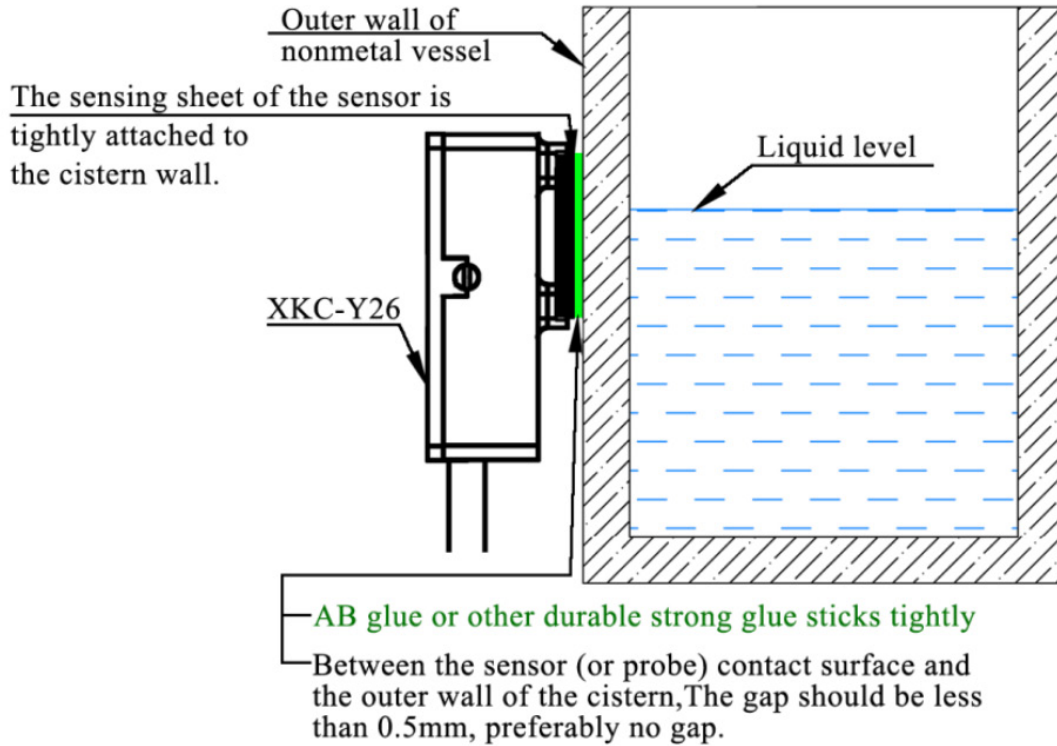

Installation method

Install into a flat cistern as shown in the figure below

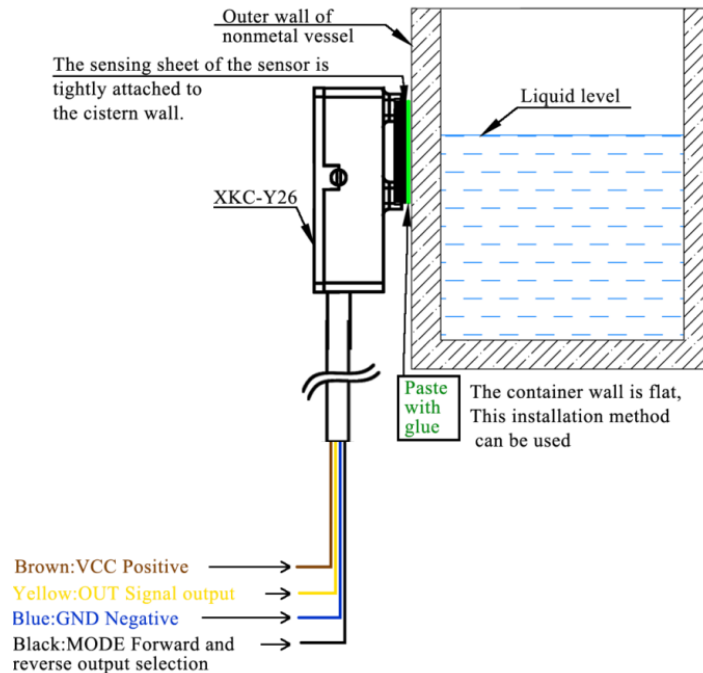

Install to the non-metal water pipe type as shown below

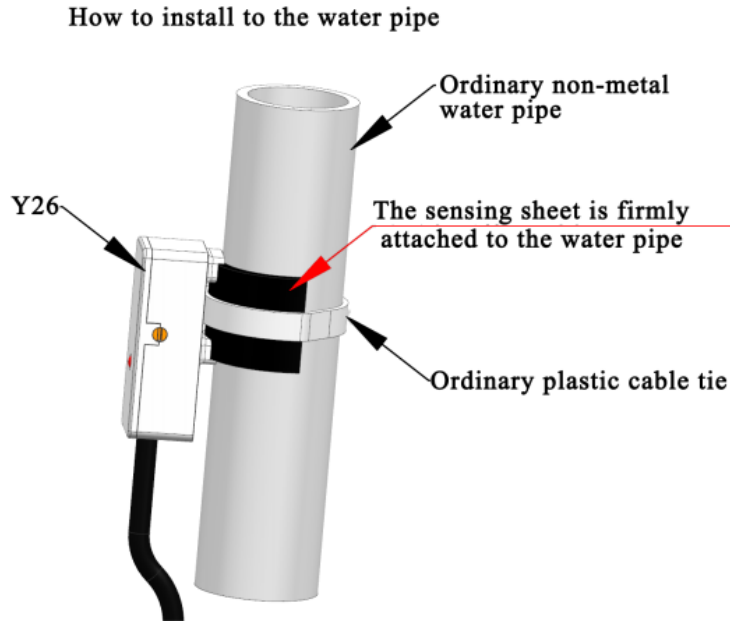

The height of the sensed liquid level is related to the sensitivity of the sensor. The higher the sensitivity, the lower the sensed liquid level

Note: The liquid level is sensed in the upper and lower edges of the sensor, which is normal.

The induction sheet can be tightly attached to the pipe with strong glue, or it can be tightened with the pipe with a nylon cable tie. There should be no metal parts in the part where the probe is installed, so as not to affect the detection. Pipes made of non-metallic materials with a smooth surface, uniform thickness, tight material, and good insulation performance; such as glass pipes, plastic pipes, PC/PVC/PPR pipes, non-absorbent ceramic pipes, acrylic pipes, rubber pipes, etc. or their composites Pipes made of materials

Sensitivity adjustment

If the non-contact liquid level sensor cannot detect or the detected liquid level deviates from the Y26 sensor, The sensitivity knob can be adjusted with a small screwdriver. Setting method:

1. Turn counterclockwise to increase sensitivity.
2. Turn clockwise to lower the sensitivity

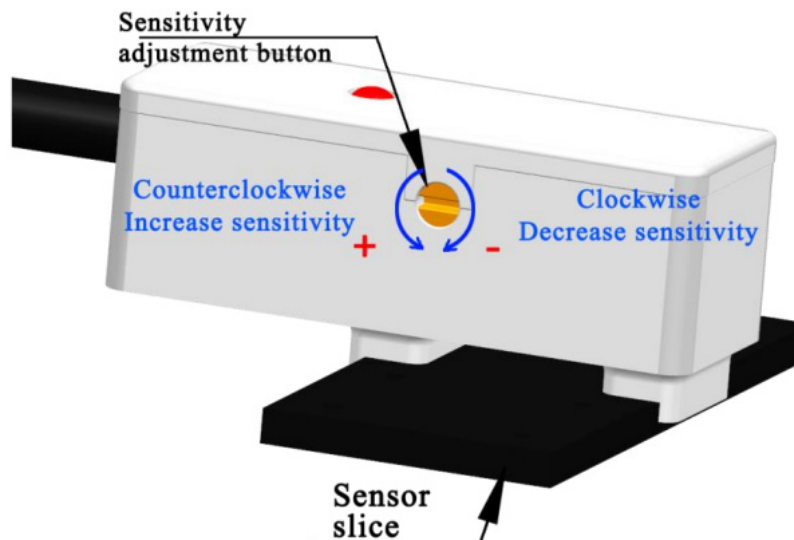

Product size

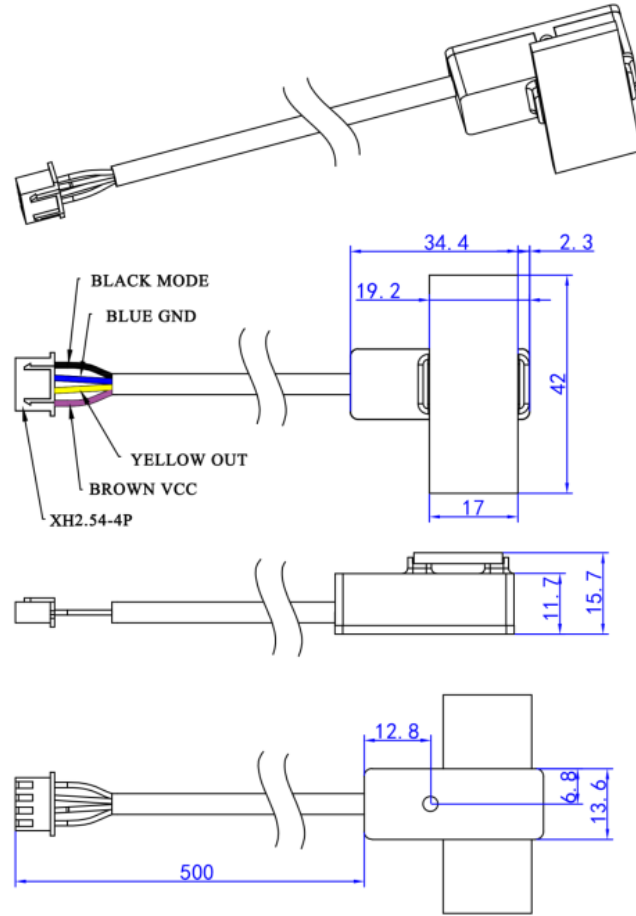

Y26 wiring diagram of various models

XKC-Y26-NPN (switch quantity type) principle and wiring method

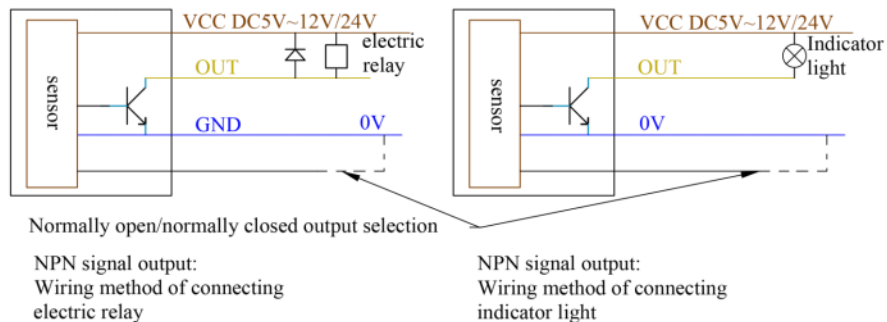
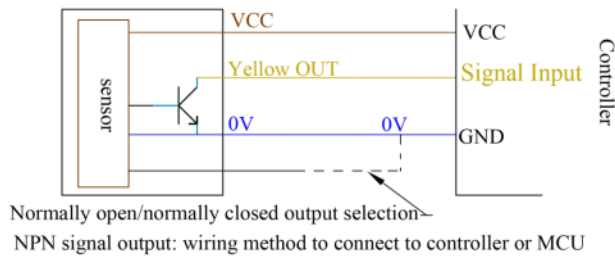
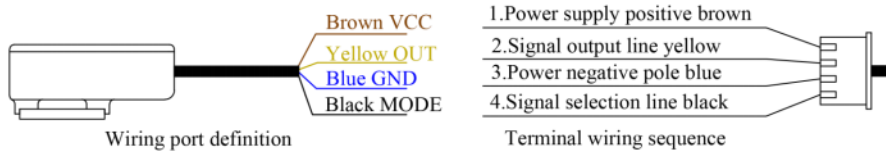

NPN output drives small electric relays (coil current $\leq 100\text{mA}$) Product Applications:

1. When the black line is suspended, it is normally open output:

When liquid is sensed, the transistor is turned on and closed, and the relay is energized and closed; When no liquid is sensed, the transistor will be cut off and the relay will not be closed when the power is turned off.

2. When the black wire is grounded (connected to the negative pole of the power supply 0V), it is normally closed output: When liquid is sensed, the transistor will be cut off and the relay will not be closed when the power is turned off; When no liquid is sensed, the transistor is turned on and closed, and the relay is energized and closed.

Other matters needing attention

(1) The viscosity of the measured liquid medium

When the dynamic viscosity is less than 10mPaS , it is measured normally. $10\text{mPaS} < \text{dynamic viscosity} < 30\text{mPaS}$ may affect the detection. When the dynamic viscosity is greater than 30mPaS , it cannot be measured because a large amount of liquid adheres to the container wall.

(2) Note: As the temperature increases, the viscosity decreases, and most high-viscosity liquids are more affected by temperature. Therefore, pay attention to the influence of liquid temperature when measuring viscous liquids.

(3) Pay attention to keeping the level gauge clean, try to prevent corrosion and avoid violent collisions and blows from other objects.

(4) During outdoor installation, avoid direct sunlight and rainwater directly flowing to the main body of the level gauge, and keep away from high heat sources and pay attention to ventilation. If the ambient temperature exceeds the rated temperature, corresponding cooling protection measures should be taken.

(5) When the ambient temperature is lower than the normal operating temperature range of the level gauge, an instrument protection box or other protective rain cap devices can be used for anti-freeze protection, and pay attention to keeping the level gauge dry. The sensor should be regularly maintained and inspected. (The detection time interval is determined by the use unit according to the specific situation).

Troubleshooting

Fault status	Analyze the reasons	Problem solving measures
After the liquid level sensor is energized, there is no response (the indicator light does not light when the water level reaches the sensing point, and the sensitivity adjustment has no response)	①The power cord is not connected	Check and connect the power
	② The positive and negative ends of the power cord are reversed	Correct wiring
	③The power module is damaged	Replace the circuit board where the power module is located
	④Sensitivity is too low	Adjust the sensitivity to the appropriate gear
The indicator light keeps on	①Sensitivity grade is too high	Adjust the sensitivity to the appropriate grade
	②The initialization parameters are abnormally modified	Return to the factory to reinitialize
	③The sensor has debris or other metal parts close to it	Clean up debris and keep a certain distance from metal parts

Product warranty terms and instructions

(A) .Warranty service

1. Warranty period maintenance: from the date of purchase, the product host has a one-year free warranty. The company has the right to decide to repair or replace the faulty part. If it is replaced, the replacement part may be a new device or a repair product of the same category, function, and quality. The replaced faulty part belongs to the company; the product Resale and repair do not affect the warranty period. Products that have been repaired or replaced continue to enjoy the original remaining warranty period service. If the warranty period is less than three months after the repair, the repaired or replaced part shall be shipped from the date of delivery Warranty for three months; all products of the company are guaranteed for repair.

2. Loss upon arrival (DOA) replacement: From the day of purchase, you can enjoy a free replacement service within 7 other hardware failures identified by our company's engineers remotely or locally.

(B). Applicable limitations of warranty

For the following situations, the company does not assume warranty responsibility:

1. The product is out of warranty; the surface of the product is fragile and damaged; the appearance of the product is seriously damaged, installation/use in abnormal environment, unauthorized disassembly and repair/modification, external power supply damage and other abnormal damage;
2. Damage caused by incorrect installation and use of the product by the user not following the requirements of the manual;
3. Damage caused by natural disasters and human negligence (fire, lightning, flooding, impact, etc.).

(C) .Accessories and consumables are not covered by the warranty.

(D) .Non-free warranty service Within two years of product purchase, for non-warranty product (including components) failures and damages, you can choose paid maintenance services (free labor costs), and we will charge the transportation cost of repairing parts and accessories according to the actual situation.